

PKE8720DF-C13-F10 Board

Specification

Rev. 1.0

Mar. 29, 2023

COPYRIGHT

©2022 PanKore Integrated Circuit Technology co. Ltd. All rights reserved. No part of this document may be reproduced, transmitted, transcribed, stored in a retrieval system, or translated into any language in any form or by any means without the written permission of PanKore Integrated Circuit Technology co. Ltd.

DISCLAIMER

Please Read Carefully:

PanKore Integrated Circuit Technology co. Ltd, (PanKore) reserves the right to make corrections, enhancements, improvements and other changes to its products and services. Buyers should obtain the latest relevant information before placing orders and should verify that such information is current and complete.

Reproduction of significant portions in PanKore data sheets is permissible only if reproduction is without alteration and is accompanied by all associated warranties, conditions, limitations, and notices. PanKore is not responsible or liable for such reproduced documentation. Information of third parties may be subject to additional restrictions.

Buyers and others who are developing systems that incorporate PanKore products (collectively, "Customers") understand and agree that Customers remain responsible for using their independent analysis, evaluation and judgment in designing their applications and that Customers have full and exclusive responsibility to assure the safety of Customers' applications and compliance of their applications (and of all PanKore products used in or for Customers' applications) with all applicable regulations, laws and other applicable requirements. Designer represents that, with respect to their applications, Customer has all the necessary expertise to create and implement safeguards that (1) anticipate dangerous consequences of failures, (2) monitor failures and their consequences, and (3) lessen the likelihood of failures that might cause harm and take appropriate actions. Customer agrees that prior to using or distributing any applications that include PanKore products, Customer will thoroughly test such applications and the functionality of such PanKore products as used in such applications.

PanKore's provision of technical, application or other design advice, quality characterization, reliability data or other services or information, including, but not limited to, reference designs and materials relating to evaluation kits, (collectively, "Resources") are intended to assist designers who are developing applications that incorporate PanKore products; by downloading, accessing or using PanKore's Resources in any way, Customer (individually or, if Customer is acting on behalf of a company, Customer's company) agrees to use any particular PanKore Resources solely for this purpose and subject to the terms of this Notice.

PanKore's provision of PanKore Resources does not expand or otherwise alter PanKore's applicable published warranties or warranty disclaimers for PanKore's products, and no additional obligations or liabilities arise from PanKore providing such PanKore Resources. PanKore reserves the right to make corrections, enhancements, improvements and other changes to its PanKore Resources. PanKore has not conducted any testing other than that specifically described in the published documentation for a particular PanKore Resource.

Customer is authorized to use, copy and modify any individual PanKore Resource only in connection with the development of applications that include the PanKore product(s) identified in such PanKore Resource. No other license, express or implied, by estoppel or otherwise to any other PanKore intellectual property right, and no license to any technology or intellectual property right of PanKore or any third party is granted herein, including but not limited to any patent right, copyright, mask work right, or other intellectual property right relating to any combination, machine, or process in which PanKore products or services are used. Information regarding or referencing third-party products or services does not constitute a license to use such products or services, or a warranty or endorsement thereof. Use of PanKore Resources may require a license from a third party under the patents or other intellectual property of the third party, or a license from PanKore under the patents or other PanKore's intellectual property.

PanKore's Resources are provided "as is" and with all faults. PanKore disclaims all other warranties or representations, express or implied, regarding resources or use thereof, including but not limited to accuracy or completeness, title, any epidemic failure warranty and any implied warranties of merchantability, fitness for a particular purpose, and non-infringement of any third party intellectual property rights.

PanKore shall not be liable for and shall not defend or indemnify Customer against any claim, including but not limited to any infringement claim that related to or is based on any combination of products even if described in PanKore Resources or otherwise. In no event shall PanKore be liable for any actual, direct, special, collateral, indirect, punitive, incidental, consequential or exemplary damages in connection with or arising out of PanKore's Resources or use thereof, and regardless of whether PanKore has been advised of the possibility of such damages. PanKore is not responsible for any failure to meet such industry standard requirements.

Where PanKore specifically promotes products as facilitating functional safety or as compliant with industry functional safety standards, such products are intended to help enable customers to design and create their own applications that meet applicable functional safety standards and requirements. Using products in an application does not by itself establish any safety features in the application. Customers must ensure compliance with safety-related requirements and standards applicable to their applications. Designer may not use any PanKore products in life-critical medical equipment unless authorized officers of the parties have executed a special contract specifically governing such use. Life-critical medical equipment is medical equipment where failure of such equipment would cause serious bodily injury or death. Such equipment includes, without limitation, all medical devices identified by the U.S.FDA as Class III devices and equivalent classifications outside the U.S.

Customers agree that it has the necessary expertise to select the product with the appropriate qualification designation for their

applications and that proper product selection is at Customers' own risk. Customers are solely responsible for compliance with all legal and regulatory requirements in connection with such selection.

Customer will fully indemnify PanKore and its representatives against any damages, costs, losses, and/or liabilities arising out of Designer's non-compliance with the terms and provisions of this Notice.

TRADEMARKS

PanKore is a trademark of PanKore Integrated Circuit Technology co. Ltd. Other names mentioned in this document are trademarks/registered trademarks of their respective owners.

USING THIS DOCUMENT

This document is intended for the software engineer's reference and provides detailed programming information.

Though every effort has been made to ensure that this document is current and accurate, more information may have become available subsequent to the production of this guide.

Contact Us

- Official website: <https://www.realmcu.com>
- Development documents: <https://www.realmcu.com/en/Home/DownloadList>
- Official forum: <https://www.realmcu.com/community/cimd>
- Sample purchase: <https://shop467975900.taobao.com>
- Business cooperation: sales@pankore.com
- Technical support: support@pankore.com

Contents

Contact Us	4
Contents	5
1 Product Overview	6
1.1 General Description	6
1.2 Characteristics	6
1.3 Application Solution	6
1.4 Main Parameters	7
2 Electrical Characteristics	8
3 RF Performance	9
3.1 Wi-Fi 2.4GHz Band RF Specification	9
3.2 Wi-Fi 5GHz Band RF Specification	9
3.3 Bluetooth LE RF Specification	10
4 Appearance Dimensions	11
5 LED and Keys	12
6 Pin Definition	13
7 Schematic Diagram	14
8 Package Information	15
Revision History	16

1 Product Overview

1.1 General Description

The PKE8720DF-C13-F10 development board is designed by Pankore for the PKM8720DF-C13-F10 module. All the module's GPIOs are pin out for the developers to develop and debug the module conveniently. Standard pin headers on both sides can also make operation easier when using bread boards for development and commissioning.

The PKM8720DF-C13-F10 is a multi-radio MCU Module. With the open CPU architecture, customers can develop advanced applications running on the dual-core 32-bit MCU. The radio provides support for Wi-Fi 802.11 a/b/g/n in the 2.4GHz/5GHz band and BLE 5.0 communications. The rich set of peripherals and high performance make it an ideal choice for smart homes, industrial automation, consumer electronics, etc.

The block diagram of PKM8720DF-C13-F10 module is illustrated in Figure 1.

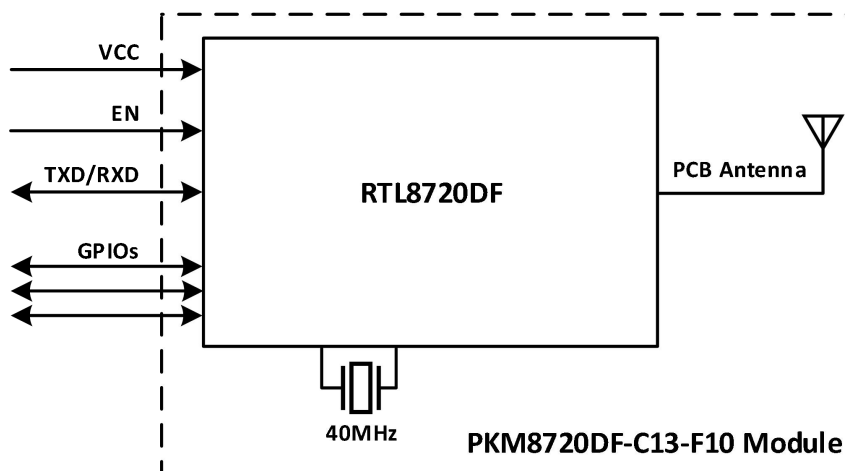

Figure 1. PKM8720DF-C13-F10 Module Block Diagram

1.2 Characteristics

- Support 802.11 a/b/g/n 1x1, 2.4GHz & 5GHz
- Support 20MHz/40MHz bandwidth, up to the data rate of MCS7
- Support low power beacons listen mode, low power Rx mode, and low power suspends mode(DLPS)
- Built-in AES/DES/SHA hardware engine
- Support Arm TrustZone-M and secure boot
- Support SWD debug port access protection and prohibition modes
- Support BLE 5.0, both central and peripheral modes
- Support Bluetooth high-power mode (maximum 10dBm)
- Internal co-existence mechanism between Wi-Fi and BT to share the same antenna
- KM4 and KM0 both have a GDMA controller, each with 6 channels

1.3 Application Solution

- Smart Homes
- Health and Fitness
- Portable Devices
- Medical
- Industrial

1.4 Main Parameters

Table 1. PKM8720DF-C13-F10 Module Main Parameters

Parameter	Description
Module Name	PKM8720DF-C13-F10
Module Package	SMD-22
Module Size	24 ± 0.2mm (L) x 16 ± 0.2mm (W) x 2.3 ± 0.1mm (H)
Antenna	On-board PCB antenna
Wi-Fi Frequency Range	<ul style="list-style-type: none">● 2412MHz ~ 2484MHz (2.4GHz ISM Band)● 5180MHz ~ 5825MHz (5GHz)
Bluetooth	BLE 5.0
Bluetooth Frequency Range	2402MHz ~ 2480MHz
Operating Temperature	-40°C to 105°C
Store Environment	-40°C to 125°C, < 90% RH
Power supply Range	(3.3 ± 10%)V, current > 450mA
Interface	UART/GPIO/ADC/PWM/I2C/SPI/SWD/USB 2.0 HS/SDIO/DMIC/IR/I2S
Module Certification	FCC/CE/SRRC

2 Electrical Characteristics

Table 2. PKM8720DF-C13-F10 Module Electrical Characteristics

Parameter condition	Min.	Typ.	Max.	Unit
DC 3.3V Supply Voltage	3.0	3.3	3.6	V
Digital I/O Supply Voltage	1.76	1.8~3.3	3.6	V
DC 3.3 Rating Current (with internal regulator and integrated CMOS PA)	-	-	450	mA
3.3V I/O Rating Current	-	-	50	mA
Electrostatic protection	-	-	2000	V

i NOTE

The PKM8720DF-C13-F10 module is electrostatic sensitive devices (ESD) and requires special ESD precautions typically applied to ESD sensitive components. Proper ESD handling and packaging procedures must be applied throughout the processing, handling, transportation and operation of any application that incorporates the PKM8720DF-C13-F10 module. Do not touch the module by hand or solder with non-anti-static soldering iron to avoid damage to the module.

3 RF Performance

3.1 Wi-Fi 2.4GHz Band RF Specification

Table 3. Wi-Fi 2.4GHz Transmitter Performance Specification

Parameter	Condition	Min.	Typ.	Max.	Unit
Frequency Range	-	2412	-	2484	MHz
Tx power at the antenna port for the highest power level (25°C)	1 Mbps DSSS	-	20	-	dBm
	11 Mbps DSSS	-	18	-	dBm
	6 Mbps OFDM	-	19	-	dBm
	54 Mbps OFDM	-	17	-	dBm
	HT20 MCS0	-	18	-	dBm
	HT20 MCS7	-	16	-	dBm
	HT40 MCS0	-	18	-	dBm
	HT40 MCS7	-	16	-	dBm
Tx EVM	1 Mbps DSSS	-	8	-	%
	11 Mbps DSSS	-	8	-	%
	6 Mbps OFDM	-	-5	-	dB
	54 Mbps OFDM	-	-25	-	dB
	HT20 MCS0	-	-5	-	dB
	HT20 MCS7	-	-28	-	dB
	HT40 MCS0	-	-5	-	dB
	HT40 MCS7	-	-28	-	dB

Table 4. Wi-Fi 2.4GHz Receiver Performance Specification

Parameter	Condition	Min.	Typ.	Max.	Unit
Frequency Range	-	2412	-	2484	MHz
802.11b Rx Sensitivity (8% PER)	1 Mbps DSSS	-	-96	-	dBm
	11 Mbps DSSS	-	-89	-	dBm
802.11g Rx Sensitivity (10% PER)	6 Mbps OFDM	-	-93	-	dBm
	54 Mbps OFDM	-	-75	-	dBm
802.11n Rx Sensitivity (10% PER)	HT20 MCS0	-	-93	-	dBm
	HT20 MCS7	-	-73	-	dBm
	HT40 MCS0	-	-91	-	dBm
	HT40 MCS7	-	-70	-	dBm

3.2 Wi-Fi 5GHz Band RF Specification

Table 5. Wi-Fi 5GHz Transmitter Performance Specification

Parameter	Condition	Min.	Typ.	Max.	Unit
Frequency Range	-	5180	-	5825	MHz
Tx power at the antenna port for the highest power level (25°C)	6 Mbps OFDM	-	17	-	dBm
	54 Mbps OFDM	-	13	-	dBm
	HT20 MCS0	-	15	-	dBm
	HT20 MCS7	-	12	-	dBm
	HT40 MCS0	-	15	-	dBm
	HT40 MCS7	-	12	-	dBm
Tx EVM	6 Mbps OFDM	-	-5	-	dB
	54 Mbps OFDM	-	-25	-	dB
	HT20 MCS0	-	-5	-	dB
	HT20 MCS7	-	-28	-	dB
	HT40 MCS0	-	-5	-	dB
	HT40 MCS7	-	-28	-	dB

Table 6. Wi-Fi 5GHz Receiver Performance Specification

Parameter	Condition	Min.	Typ.	Max.	Unit
Frequency Range	-	5180	-	5825	MHz
802.11g Rx Sensitivity (10% PER)	6 Mbps OFDM	-	-91	-	dBm
	54 Mbps OFDM	-	-74	-	dBm
802.11n Rx Sensitivity (10% PER)	HT20 MCS0	-	-91	-	dBm
	HT20 MCS7	-	-72	-	dBm
	HT40 MCS0	-	-89	-	dBm
	HT40 MCS7	-	-69	-	dBm

3.3 Bluetooth LE RF Specification

Table 7. Bluetooth LE Transmitter Performance Specification

Parameter	Condition	Min.	Typ.	Max.	Unit
Frequency Range	-	2402	-	2480	MHz
Tx Output Power	LE1M	-10	4.5	10	dBm
	LE2M				

Table 8. Bluetooth LE Receiver Performance Specification

Parameter	Condition	Min.	Typ.	Max.	Unit
Frequency Range	-	2402	-	2480	MHz
Rx Sensitivity @30.8% PER	LE1M	-	-99	-	dBm
	LE2M	-	-95	-	

4 Appearance Dimensions

Board dimension: 46.6 ± 0.2mm (L) x 25.4 ± 0.2mm (W) x 3.3 ± 0.2mm (H)

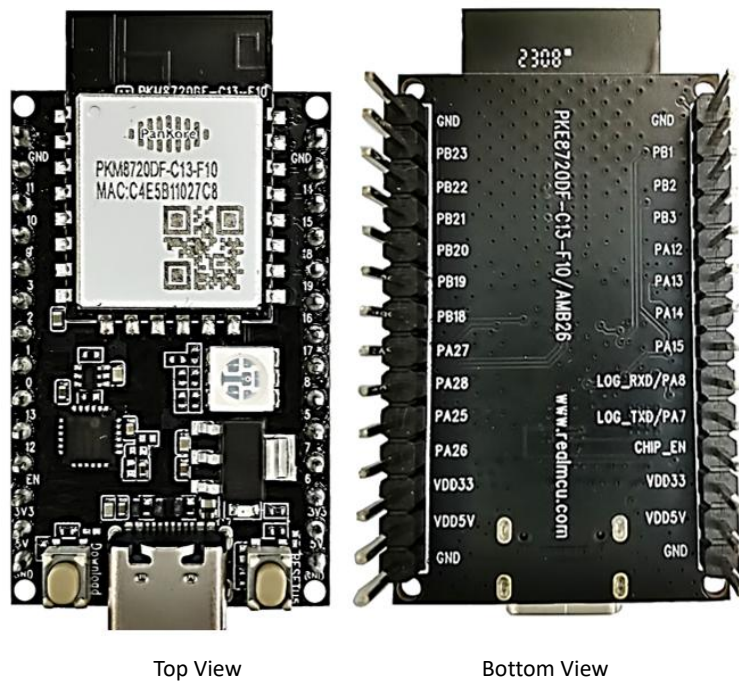

Figure 2. PKE8720DF-C13-F10 Board Appearance

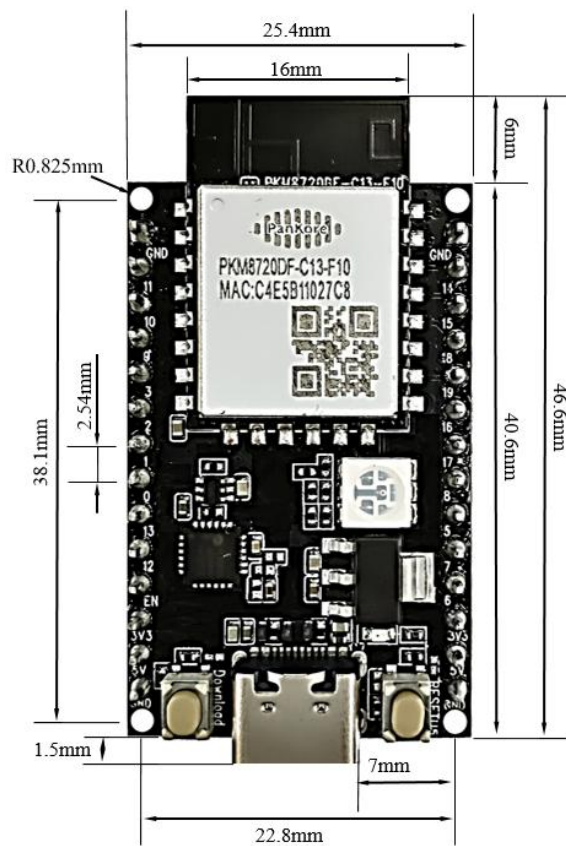

Figure 3. PKE8720DF-C13-F10 Board Dimensions

5 LED and Keys

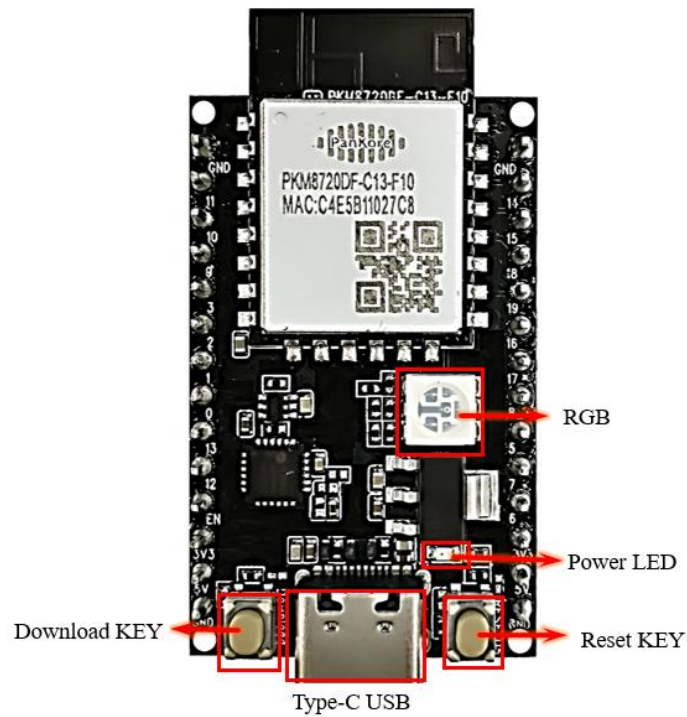

Figure 4. LED and Keys

Table 9. Information of LED and Keys

LED & Keys	Function	Note
Power LED	3.3 V power light	LED lights up when 3.3V is available.
RGB	RGB light	The red, blue and green colors are controlled by PA12, PA13 and PA14
Reset KEY	Reset button	-
Download KEY	Set the module to download mode	Follow these steps to enter the download mode: (1) Press and hold the Download KEY (2) Press the Reset KEY and release it (3) Release the Download KEY

6 Pin Definition

The PKE8720DF-C13-F10 development board leads out 19 I/O interfaces. Figure 5 describes the board interfaces, and the pin function definition table is also layout to list the interface definition.

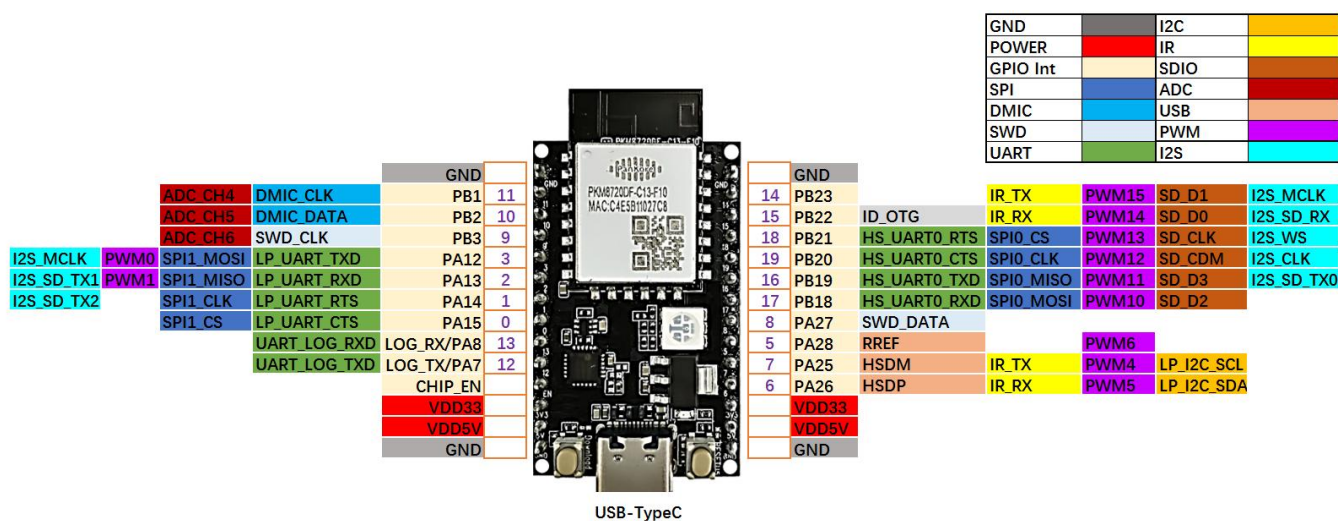

Figure 5. PKE8720DF-C13-F10 Board Interface Description

Table 10. PKE8720DF-C13-F10 Board Pin Definition

Pin No.	Pin Name	Description
0	PA15	LP_UART_CTS/SPI1_CS
1	PA14	LP_UART_RTS/SPI1_CLK/I2S_SD_TX2
2	PA13	LP_UART_RXD/SPI1MISO/PWM1/I2S_SD_TX1
3	PA12	LP_UART_TXD/SPI1_MOSI/PWM0/I2S_MCLK
4	-	-
5	PA28	RREF/PWM6
6	PA26	HSDP/LP_I2C_SDA/PWM5/IR_RX
7	PA25	HSDM/LP_I2C_SCL/PWM4/IR_TX
8	PA27	SWD_DATA
9	PB3	SWD_CLK/ADC_CH6
10	PB2	DMIC_DATA/ADC_CH5
11	PB1	DMIC_CLK/ADC_CH4
12	LOG_TX/PA7	UART_LOG_TXD
13	LOG_RX/PA8	UART_LOG_RXD
14	PB23	IR_TX/PWM15/SD_D1/I2S_MCLK
15	PB22	ID_OTG/IR_RX/PWM14/S_D0/I2S_SD_RX
16	PB19	HS_UART0_TXD/SPI0_MISO/PWM11/SD_D3/I2S_SD_TX0
17	PB18	HS_UART0_RXD/SPI0_MOSI/PWM10/SD_D2
18	PB21	HS_UART0_RTS/SPI0_CS/PWM13/SD_CLK/I2S_WS
19	PB20	HS_UART0_CTS/SPI0_CLK/PWM12/SD_CDM/I2S_CLK

NOTE

If user wants to use the USB function, RREF needs to be connected to a resistor (12kohm, 1%) in series to the ground.

7 Schematic Diagram

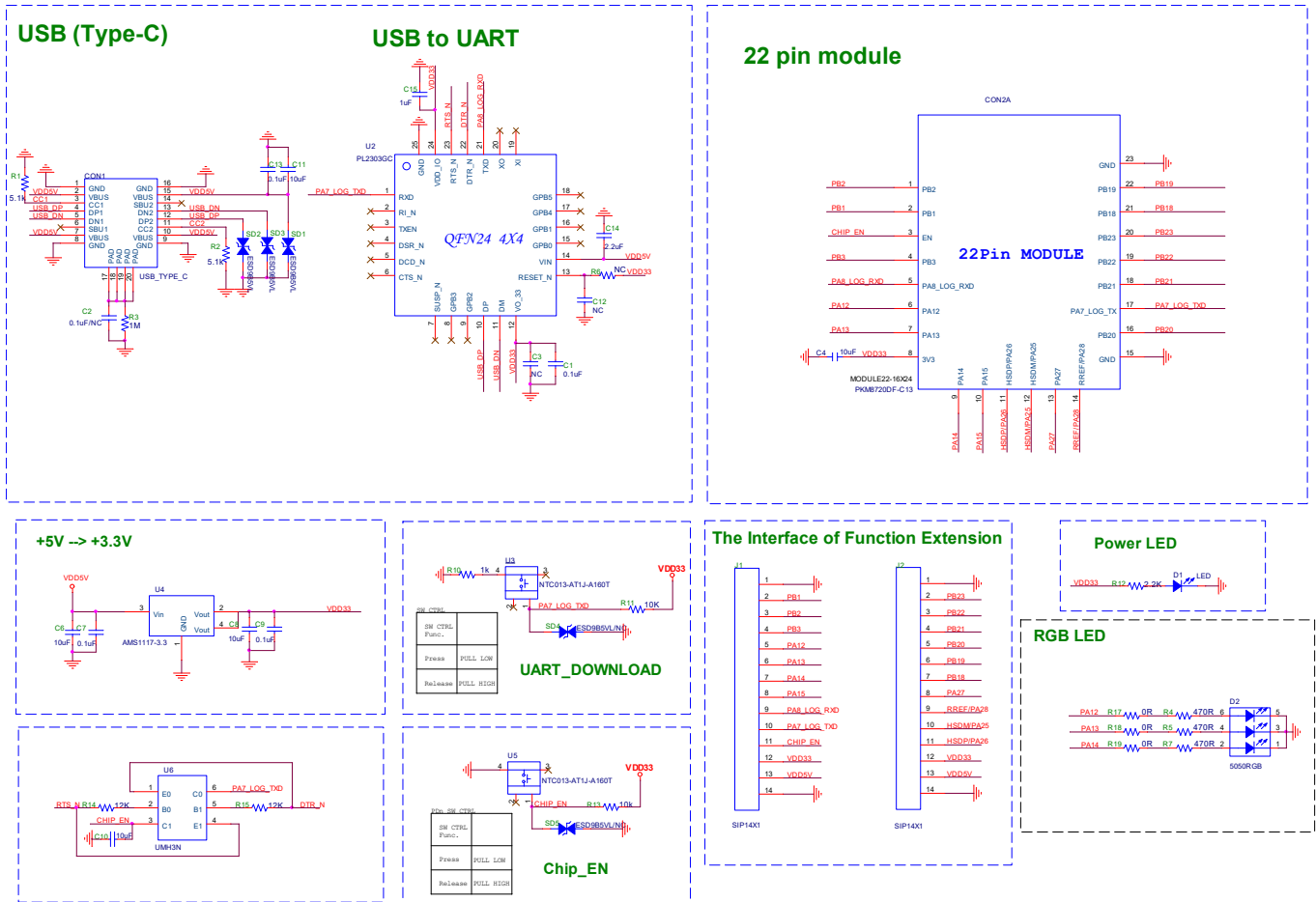

Figure 6. PKE8720DF-C13-F10 Schematic Diagram

8 Package Information

The PKE8720DF-C13-F10 development board is packaged for inserted pearl cotton with electrostatic bags.

Revision History

Data	Revision	Summary
2023-03-29	1.0	Initial release